

DENAFRIPS

ARES 15th user's manual

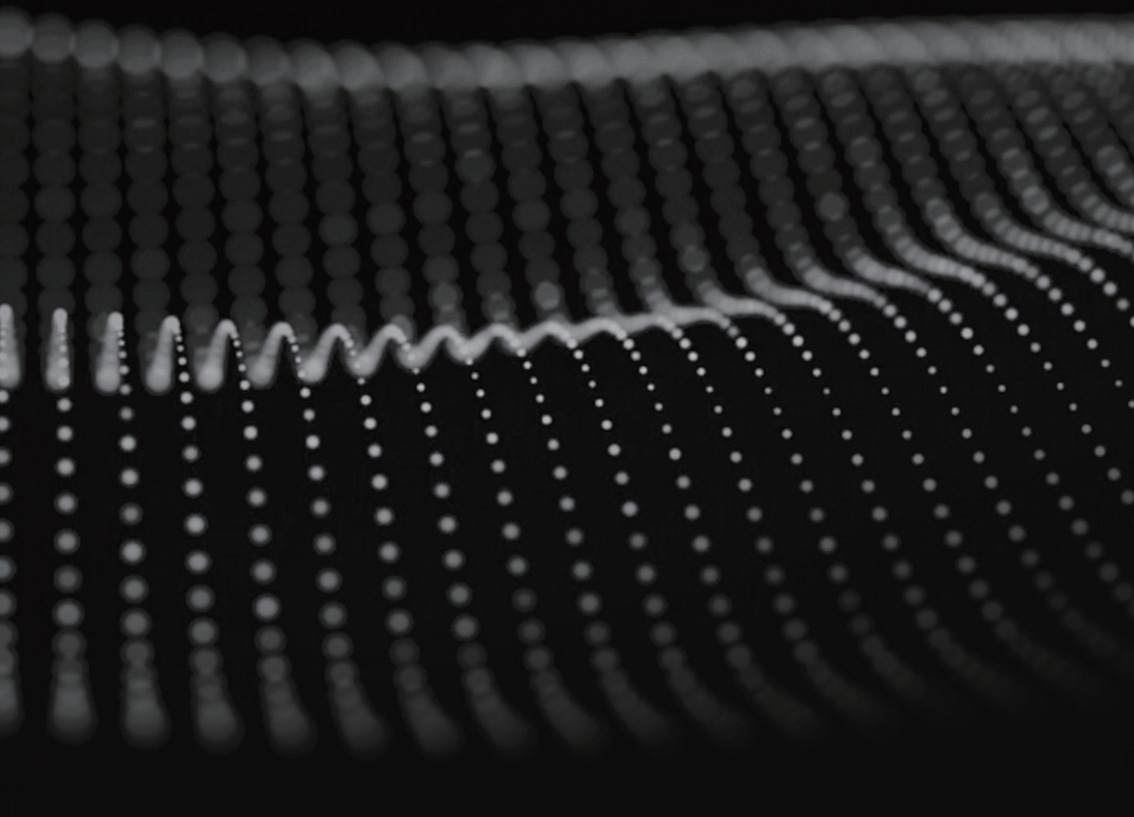

Table of Contents

Product Overview.....	3
Function Panel Introduction.....	4
Operation Settings.....	8
technical specification.....	11
Backplane Interface Introduction.....	12
USB Driver Installation.....	13
Common Troubleshooting.....	14
after-sales service.....	16
Important protective measures to be aware of.....	18

Functional features

1. Proprietary R2R + DSD architecture
2. Low thermal effect, high-precision hand-matched 0.1% resistors
3. LPNO crystals at 45.1548MHz and 49.152MHz
4. Low-noise power supply
5. FIFO buffer
6. Digital signal processing through FPGA
7. USB/I2S input supports DSD1024, USB supports PCM1536KHz, I2S supports PCM768KHz(Audio source must be compatible with the unit's interface)
8. Proprietary USB audio solution based on STM32F446 advanced ARM MCU
9. Thesycon USB driver licensed for Windows platform
10. No driver required for Mac and Linux platforms

DSD

1. All inputs support DSD64-DoP
2. USB and I2S inputs support DSD1024

PCM

1. All inputs support 24bit/support 192KHz
2. USB input support 1536KHz, I2S input support 768KHz

sampling mode

Original code rate NOS/Oversampling OS

Function Panel Introduction

Figure 1

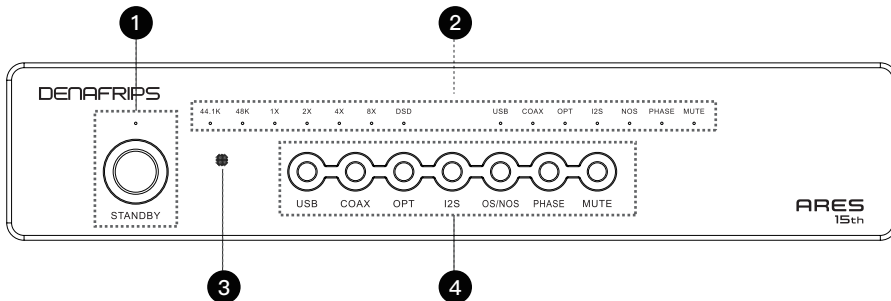

❶. Standby button and indicator

When the power of the unit is turned on, the standby indicator light is on, indicating that it is in standby mode. Press the standby button, the standby indicator goes out and the DAC starts to work.

❷. Indicators on the DAC panel (showing input source, sample rate, audio format and mode).

a. Signal source indicators: USB, COAX, OPT, I2S. These indicators indicate different input ports. When an input source is selected, the corresponding indicator lights up.

b. Sample rate indicators: 44.1K (44.1 KHz sample rate); 48K (48 KHz sample rate). These indicators indicate the current sample rate of the input audio signal.

c. Multiplier indicators: 1X (original sample rate); 2X (2 times the sample rate); 4X (4 times the sample rate); 8X (8 times the sample rate). These indicators show the multiplier frequency of the current input audio signal (e.g. a multiple of the original sample rate, as explained in the following chart).

d. Audio format indicator: DSD when the light is on, PCM when the light is off.

e. PHASE indicator: In-phase when the light is on, inverted when the light is off.

f. NOS indicator: NOS when the light is on, OS when the light is off.

In OS mode, the DAC processes the incoming digital audio signal to increase the sampling rate. Oversampling increases the audio quality by adding more data points through interpolation algorithms. In NOS mode, the DAC processes the input digital audio signal directly without any sample rate processing. This mode preserves the original characteristics of the audio signal.

g. MUTE indicator: mute when the light is on, normal audio output when the light is off.

3. Remote Control Receiver Window

The remote control receiving signal window , cannot be blocked, otherwise it will affect the remote control receiving signal.

Kind Reminder: The DAC device does not come with a remote control, which needs to be purchased separately.

Schematic diagram of the effective working angle and distance range of the remote control.

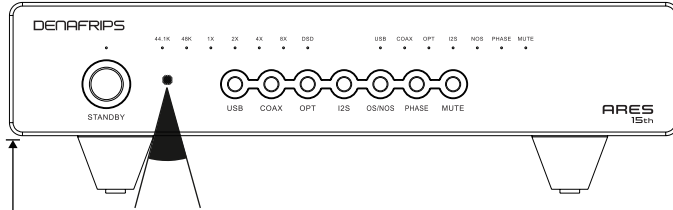

Receiving end: a cone range of plus or minus 30 degrees on the axis of the IR receiving window;

Effective remote control
Distance: $\leq 8m$

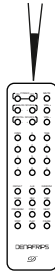

Emitter: A cone range of plus or minus 10 degrees on the axis of the infrared emitter tube;

4. control key

a. STANDBY, USB, COAX, OPT, I2S, OS/NOS, PHASE, and MUTE. press these buttons for direct control of the audio input source, phase, sample mode, mute, and operating mode.

b. Description of each key

STANDBY (❶ in Fig. 1) Standby button: press the standby power button, the standby indicator in Fig. 1 goes out and the DAC starts to work; conversely, the light is on to indicate that the DAC handles the standby state.

USB button: The indicator light indicates that the current audio source is a USB input source.

COAX button: The indicator light indicates that the current audio source is the COAX input source.

OPT button: The indicator light indicates that the current audio source is the OPT input source.

I2S button: Indicates the current audio source is an I2S input source.

OS/NOS Button: This is the switch for selecting between native sampling and oversampling. When the button is pressed and the light is on, it indicates NOS (native sampling); when the light is off, it indicates OS (oversampling).

PHASE button: Phase selector switch, when this button is pressed, the light is on for in-phase output and off for inverted output.

MUTE button: When this button is pressed, all the audio source indicators are flashing.

The relationship between the sampling rate of the input audio signal and the display of the panel indicators is shown in Table 1 below.

Basic Sampling Rate	multiplier	input format
44.1 KHz	1X	44.1 KHz
	2X	88.2 KHz
	4X	176.4 KHz
	8X	352.8 KHz
	$16X = 2X + 8X$	705.6 KHz
	$32X = 4X + 8X$	1411.2 KHz
48 KHz	1X	48 KHz
	2X	96 KHz
	4X	192 KHz
	8X	384 KHz
	$16X = 2X + 8X$	768 KHz
	$32X = 4X + 8X$	1536 KHz
DSD	1X	DSD 64
	2X	DSD 128
	4X	DSD 256
	8X	DSD 512
	$16X = 2X + 8X$	DSD 1024

Operation Settings

Function Setting	procedure
A. USB upgrade settings	<ol style="list-style-type: none">1. Select USB input, press the MUTE button, the indicator light is on.2. Press the USB button, the indicator light flashes, indicating that it enters the software upgrade mode.3. Power off and restart after the upgrade is completed.
B. I2S Pinout (Note: turn down the volume before debugging the pins)	<ol style="list-style-type: none">1. Select I2S Input .2. Press the MUTE button, the indicator light indicates entering the setting mode.3. Momentarily switch I2S button (within 3s) to switch I2S mode on, press I2S button repeatedly to select match mode, 1X, 2X, 4X will be turned on/off in fixed mode (indicates binary 000–111).4. Wait 10 seconds.5. DAC returns to its original state.
C. Filter Selection (valid only in the operating system)	<ol style="list-style-type: none">1. Press the MUTE button and the indicator lights up to indicate entry into setup mode.2. momentarily toggle the OPT button (within 3s) to open the filter setup, press the OPT button repeatedly and the filter will toggle back and forth between the slow filter and the fast filter.3. 1X indicator on = slow filter, 1X indicator off = fast filter.4. Wait 10 seconds.5. The DAC returns to its original state.

Function Setting	procedure
<p>D. DSD left and right channel switching</p>	<ol style="list-style-type: none"> 1. Press the MUTE button and the indicator lights up to enter configuration mode. 2. Switch the NOS button momentarily (within 3s) to open the channel switching setting. 3. Press the NOS button repeatedly to switch the left and right channels back and forth.
<p>E. Selection Oversampling Rate / Original code rate</p>	<ol style="list-style-type: none"> 1. Press the NOS/OS button. 2. NOS indicator on = original code rate, NOS indicator off = oversampling rate.
<p>F. Source Selection</p>	<p>USB, COAX (coaxial), OPT and I2S.</p> <p>Press these buttons to select the input source and the corresponding source indicator will light up.If a device has more than one audio source input, press the corresponding audio source input button.indicator lights up to indicate successful switching.</p>

Table 3: I2S Pin Diagram (The machine is shipped in mode ‘1’, all lamps are off, ‘○’ = lamps off, ‘●’ = lamps on)

Mode	LED on & off Relationship Diagram			I2S PINOUT						
	1X	2X	4X	PIN	DATA		BCK		LRCK	
	DATA	BCK	LRCK	Mode	1	3	4	6	7	9
1	○	○	○	1	DATA-	DATA+	BCK+	BCK-	LRCK-	LRCK+
2	●	○	○	2	DATA+	DATA-	BCK+	BCK-	LRCK-	LRCK+
3	○	●	○	3	DATA-	DATA+	BCK-	BCK+	LRCK-	LRCK+
4	●	●	○	4	DATA+	DATA-	BCK-	BCK+	LRCK-	LRCK+
5	○	○	●	5	DATA-	DATA+	BCK+	BCK-	LRCK+	LRCK-
6	●	○	●	6	DATA+	DATA-	BCK+	BCK-	LRCK+	LRCK-
7	○	●	●	7	DATA-	DATA+	BCK-	BCK+	LRCK+	LRCK-
8	●	●	●	8	DATA+	DATA-	BCK-	BCK+	LRCK+	LRCK-

Figure 2: HDMI I2S Input Diagram

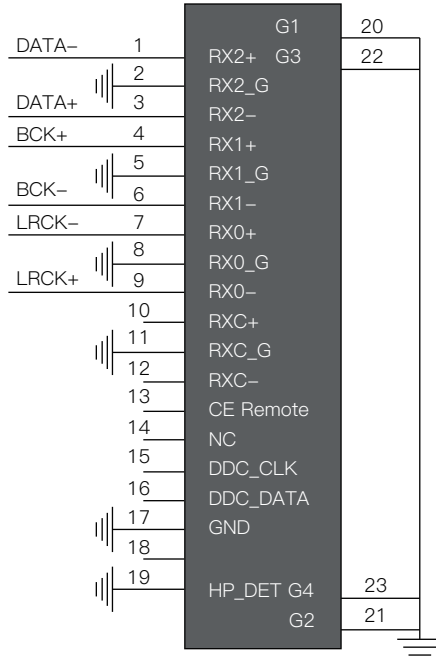

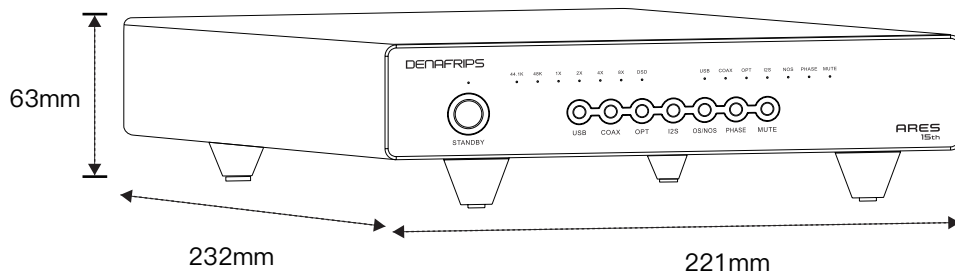

(OPT input test):

Analog Output Level:	RCA: 2.0Vrms; XLR: 4Vrms
Analog Output Impedance:	RCA: 625Ω; XLR: 1250Ω
Frequency Response:	20Hz–70KHz (+1/–3dB)
Distortion:	< 0.0020% (A-weighted)
Signal-to-Noise Ratio:	> 115dB (A-weighted)
Dynamic Range:	> 119dB
Stereo Crosstalk:	> –110dB
AC Power Requirements:	115V/60Hz, 230V/50Hz (Global voltage, manually selectable)
Fuse:	T2A/250VAC, 5x20mm 2A slow-blow fuse
Total Power Consumption:	< 20W
Machine Dimensions:	221 x 232 x 63mm (including feet)
Outer Packaging Dimensions:	W385 x D335 x H120mm
Packaging Accessories:	Power cable, manual, and warranty card
Net Weight:	3.2 kg
Gross Weight:	4.6 kg

Backplane Interface Introduction

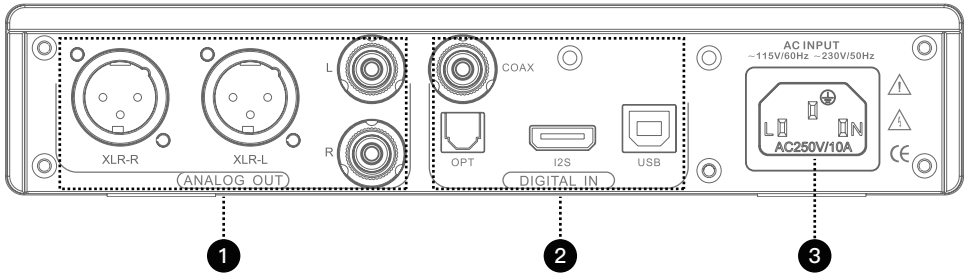

❶. Analogue audio signal output area, the unit has a pair of XLR outputs, a pair of RCA outputs, according to your equipment, choose the appropriate output.

XLR-R: Analogue signal right channel balanced output.

XLR-L: Analogue signal left channel balanced output.

RCA-R: Analogue signal right channel balanced output.

RCA-L: Analogue left channel balanced output.

Note: The RCA outputs are connected in parallel to the positive end of the XLRs. In order not to affect your listening experience, we don't recommend you to use the RCA and XLR outputs at the same time.

❷. Digital audio input connector area.

The unit has 4 input interfaces, namely COAX, OPT, I2S and USB.

COAX: (Coaxial) digital interface, interface transmission is stable, suitable for short distance connection, provides high audio quality.

OPT: OPT digital input interface.

I2S: (HDMI standard cable) input interface. The wiring order may vary between manufacturers, and this unit offers 8 wiring configurations to match different manufacturers. For detailed instructions, please refer to the function setting guide. Note: Do not plug or unplug this cable while the machine is powered on to avoid potential damage from static electricity.

USB: (Universal Serial Bus) interface, providing convenient digital audio transmission and allowing high-fidelity audio data transfer. It is suitable for connection to PCs, Macs, and various digital audio devices.

❸. Power input connector.



This unit is a Class I device, which requires a 3-core power cord, and you need to ensure that the power supply is well grounded; by using the power input connector correctly, you can ensure that the DAC equipment receives stable and reliable power support.

USB Driver Installation

USB Driver Installation – The USB driver is required for Windows operating systems (win10 or above only, for versions below win10 refer to the official website for detailed instructions). The USB driver is licensed by THESYCON and is designed to provide the highest quality audio playback for computer audio systems.

Note: Mac and Linux operating systems do not require a USB driver.

Installation Guide

1. Do not connect the USB cable from your computer to the DAC. unplug it before the USB driver is installed.
2. Download the driver from the support page at <https://www.denafrips.com/download-thesycon>.
3. Double-click the driver on your computer → Follow the on-screen instructions to complete the installation
4. Restart your computer → Connect the USB cable to the DAC → Find the driver icon in the bottom right corner of your computer 
5. Click on the driver icon → select USB Input
6. Click on Playback Devices in the bottom right corner of your computer 
→ Select DENAFRIPS USB DAC as the default sound card for Windows OS.
7. Driver, finish

Solutions to common faults

Phenomenon	Solution
A. No sound output	<ol style="list-style-type: none">1. Check that all input and output connection cables are properly connected.2. Check the volume setting of the audio source to ensure that it is not set to mute and that the volume is moderate.3. Replace the data cable or cables to ensure there is no damage.4. Make sure the input source is the same as the panel selection.5. Make sure the unit is not in 'MUTE' state.
B. Noise or murmur	<ol style="list-style-type: none">1. Use the power cord and power adapter to ensure stable power supply.2. Check all connecting cables and interfaces to ensure good contact.3. Try to avoid placing the DAC in areas with high electromagnetic interference, such as near power lines or wireless devices.
C. sound quality distortion	<ol style="list-style-type: none">1. Make sure the sample rate and format of the input signal match the format supported by the DAC.2. Adjust the DAC's filter and decoder settings to select the appropriate sound quality mode.3. Check all signal cables and connectors to make sure the connections are firm and undamaged.

Phenomenon	Solution
<p>D. Device cannot be switched on</p>	<ol style="list-style-type: none"> 1. Check that the power cord and power adapter are properly connected, and make sure there is power to the power outlet. 2. Try restarting the DAC, or reconnecting the power supply after a power failure. 3. If the problem persists, you can contact the manufacturer and we provide detailed solutions.
<p>E. Input signal not recognised</p>	<ol style="list-style-type: none"> 1. Ensure that the format and sampling rate of the input signal matches the format supported by the DAC. 2. Check the input connector and connecting wires to make sure there is no damage or poor contact.
<p>F. The computer cannot recognize the USB device.</p>	<ol style="list-style-type: none"> 1. Ensure that the latest USB driver for the DAC is installed. 2. Check the USB cable and port to make sure the connection is good and undamaged. 3. Try replacing the USB cable or using a different USB port.

After-sales instructions

Dear users: Thank you for purchasing our products! In order to ensure that you get the best experience, please read the following after-sales service related instructions carefully.

1. Warranty

- ①. Warranty period: 1 year free warranty service.
- ②. Warranty contents

Phenomenon	Solution
a. Warranty period, the product normal use of non-human factors any product quality or functional problems.	Please contact us or your local agent service centre for repair with the serial number on the warranty card. DENAFRIPS offers free repair or replacement parts service and covers all shipping costs.
b. The product is out of warranty and there are any problems with the quality or functionality of the product.	DENAFRIPS offers a paid repair service. If replacement parts are required, only the cost price of the parts (labour is free) and the return logistics costs will be charged.
c. Problems with product quality or function due to improper use or other human factors.	This situation is not covered by the warranty, DENAFRIPS offers a paid repair service, if replacement parts are required, only the cost price of the parts will be charged, labour is free of charge and the user is responsible for the return shipping costs.

- ③. WARRANTY PROCESS: DENAFRIPS has about 30 repair outlets around the world, in order to save shipping costs, the official will co-ordinate with the nearest repair outlets to serve you.

After-sales instructions

④. The following are not covered by the free warranty

- a. The product has exceeded the specified warranty period from the date of purchase.
- b. The physical product does not match the product model, bar code and date of purchase on the warranty card.
- c. The product has been modified or repaired without the authorisation of DENAFRIPS technical staff.
- d. Damage caused by human factors (e.g. dropping, impact, immersion in water, fire, etc.).
- e. Damage caused by irresistible natural forces (such as earthquakes, floods, lightning strikes, etc.).
- f. Damage caused by exceeding the permitted usage environment.
- g. Damage caused by incorrect use or improper storage (including but not limited to: excessive voltage caused by wiring or component burns; collision caused by the shell or internal device damage; damage caused by excessive dust; product oxidation or corrosion, etc.).

2. Return Policy

- ①. Return conditions: Users can apply for a return within 14 days after receiving the product, if the product has quality problems that are not caused by human damage. Return shipping costs will be borne by the merchant. Please ensure that the product appearance is undamaged, complete accessories, packaging intact, and provide proof of purchase.
- ②. Exchange conditions: During the warranty period, if the product is identified as a quality problem and cannot be repaired, DENAFRIPS will provide an exchange service and bear all the costs.

3. Important Notes

- ①. Please keep your warranty card, it is very important. The serial number of the warranty card is the same as the serial number of the product, which is used as the evidence to enjoy the after-sales service.
- ②. For further information about after-sales policy, please visit our website or contact customer support.

Important protective measures to be aware of



warnings



Risk of electric shock inside the unit. Do not open the cover.

- To minimise the risk of electric shock, do not remove the outer cover (or back cover).
- If repairs are necessary, they should be carried out by qualified service personnel.
- To avoid fire and electric shock hazards, do not allow the unit to get wet or damp.

- ①. **Read Protective Measures**—Before using the equipment, carefully read all warning information in the instruction manual regarding protection and operation.
- ②. **Follow the instructions for use**—Please follow the operation and use information in the instruction manual, and do not operate in violation of the instruction manual.
- ③. **Keep away from water and humidity**—Do not place the unit near water, such as bathtubs, washbasins, sinks, washing machines, etc.; and do not use it in high-temperature and high-humidity environments, such as damp basements.
- ④. **cleanse**—Do not use liquid cleaners and mist cleaners, clean with a dry cloth. Unplug the unit before cleaning.
- ⑤. **power supply**—Please use the power supply according to the labelling of the product. The wiring should be arranged reasonably, please do not step on the line, pulling the power cord, so as not to cause damage. Pay special attention to the wires of plugs, convenient sockets and equipment connections.
- ⑥. **Heat Dissipation**—In order to ensure that the product is used reliably, overheating of the device should be avoided, please do not cover cover the device. Do not use the product on surfaces similar to beds, sofas, carpets and other similar surfaces. If the appliance is installed built-in, such as in a bookcase or on a shelf, make sure there is adequate ventilation. Keep a distance of 10cm (4") on each side, above and behind the appliance. The rear edge of the appliance bracket or upper cover should be 10cm(4") away from the rear panel or wall to allow space for ventilation and heat dissipation.
- ⑦. **Thermal energy**—Keep the product away from heat sources such as radiators, stoves, and other objects that generate heat (including power amplifiers).

⑧. **Prevent foreign objects or liquids**—Please avoid allowing objects or liquids to enter the device through any openings, as contact with live components may cause a fire or electric shock hazard. Do not place this device in environments where it may be exposed to rain or splashing liquids, and avoid placing containers with liquids (such as vases) on the device.

⑨. **Lightning**—During thunderstorms, please unplug the power cord to effectively prevent damage from lightning strikes.

⑩. **Protection**—Disconnect the power plug when the product is not used for a long period of time.

⑪. **protect and maintain**—Users themselves should not open the device's shell to avoid electric shock. In the following cases, if you need repair, please contact the official or professional repair outlets to dismantle the machine.

⑫. **Disconnecting device**—When the plug, appliance coupler, and power switch are used as the disconnecting device, ensure easy operation.

DENAFRIPS

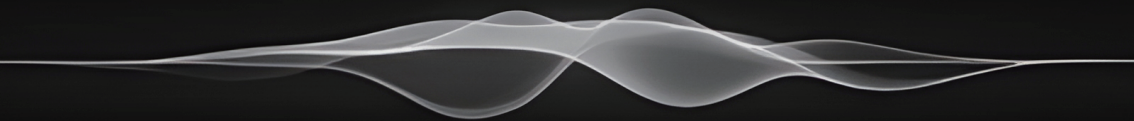

✉ support@denafrips.com

🌐 <https://www.denafrips.com/>

📺 <https://www.youtube.com/@DENAFRIPSAudio>



Facebook